

# Quantum transport and counting statistics in closed systems<sup>1</sup>

Maya Chuchem, Doron Cohen

*Department of Physics, Ben-Gurion University, Beer-Sheva 84105, Israel*

---

## Abstract

A current can be induced in a closed device by changing control parameters. The amount  $Q$  of particles that are transported via a path of motion, is characterized by its expectation value  $\langle Q \rangle$ , and by its variance  $\text{Var}(Q)$ . We show that quantum mechanics invalidates some common conceptions about this statistics. We first consider the process of a double path crossing, which is the prototype example for counting statistics in multiple path non-trivial geometry. We find out that contrary to the common expectation, this process does not lead to partition noise. Then we analyze a full stirring cycle that consists of a sequence of two Landau-Zener crossings. We find out that quite generally *counting* statistics and *occupation* statistics become unrelated, and that quantum interference affects them in different ways.

*Key words:* Quantum transport, Topological effects, Ahraonov-Bohm geometry, Adiabatic processes, Landau-Zener transitions, Interference, Quantum stirring

*PACS:* 03.65.-w, 03.65.Ta, 73.23.-b, 05.60.Gg

---

## 1. Introduction

Consider a closed isolated quantum system, say a 3 site ring as in Fig.1. Quite generally, in the absence of magnetic field, the stationary states of the system carry zero current. If one wants to have a non-zero current  $I$  through a section of the device, one has either to prepare it in a non-stationary state or to drive the system. Driving means changing some parameters in time. During a time period  $t$  the amount of particles that get through the section is  $Q$ . One may ask what is the distribution of the measured  $Q$ , and in particular what is the expectation value  $\langle Q \rangle$ , and what is the variance  $\text{Var}(Q)$ . This is known as *counting statistics* [3–5].

Typically the driving is periodic, and  $Q$  is defined as the amount of particles that are transported per period. The feasibility to have non-zero  $Q$  (non zero “DC” current) due to periodic (“AC”) driving is known in the context of open geometry as “quantum pumping” [1,2]. We use the term “quantum stirring” [6,7] in order to describe the analogous effect with regard to a closed device [8].

The theory of quantum pumping and counting statistics in open geometries is well studied. Any attempt to adopt ideas from this literature to the present context of quantum stirring is dangerous, and likely to result in *major misconceptions*, which following [9,10] we would like to highlight. For this purpose let us consider the simplest model that can be imagined: a particle in a 3-site system (Fig.1). We assume that

---

<sup>1</sup> Physica E **XX**, XXX (2009). Special issue. Proceedings of FQMT conference (Prague, 2008).

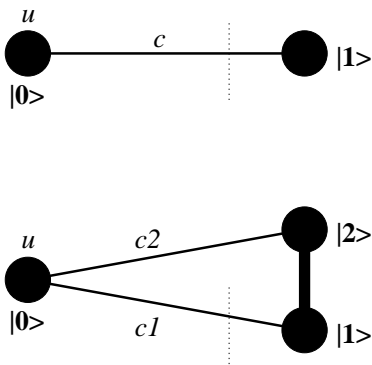

Fig. 1. Toy models that are analyzed in this paper: a particle in a 2 site system (upper illustration), and a particle in a 3 site system (lower illustration). Initially the particle is prepared in the  $|0\rangle$  site where it has a potential energy  $u$ . The hopping amplitudes per unit time (the  $c$ s) are also indicated. In the case of a 3 site system, the time units are chosen such that the hopping amplitude per unit time between  $|1\rangle$  and  $|2\rangle$  equals unity, while the other amplitudes are assumed to be small ( $|c_1|, |c_2| \ll 1$ ). The current is measured through the dotted section.

we have a control over the potential  $u$  of the left site, and over the couplings  $c_1$  and  $c_2$  that bind the left site to the right sites. The transported  $Q$  is measured through one of these two bonds. Let us introduce two simple questions that will be answered later on.

**Question 1.** – We start with a very negative  $u$  and prepare a particle in the left site. Then we gradually raise  $u$  so as to have an *adiabatic* transfer of the particle to the right side. If we had  $c_1 \neq 0$  but  $c_2 = 0$  one obviously expects in the strict adiabatic limit  $Q = 1$  with zero variance. We ask: what would be the corresponding result if we have  $|c_1| = |c_2|$ , and more generally how does the result depend on the relative size of the couplings? If the  $|c_1|$  coupling is larger, does the result reflect having (say)  $Q = 1$  with 70% probability and  $Q = 0$  with 30% probability?

**Question 2.** – During a cycle a conventional pump takes an electron from the left lead and ejects it to the right lead. Hence the pumped charge per cycle for a leaky pump is  $Q < 1$ . Now we integrate this quantum pump into a closed circuit and operate it. We ask what is the statistics of  $Q$  in the new (integrated) configuration. Can it be much different? What are the maximal  $\langle Q \rangle$  and minimal  $\text{Var}(Q)$  that can be achieved per cycle? Are they both proportional to the number of the cycles as in the classical reasoning, leading to  $\sim \sqrt{t}$  sig-

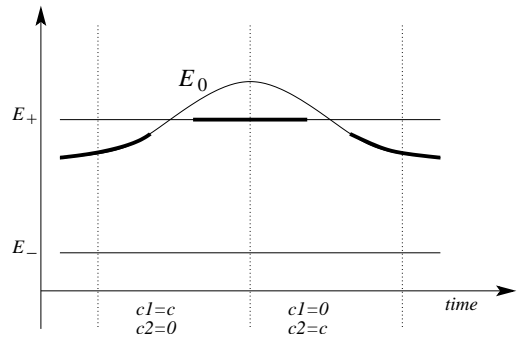

Fig. 2. The adiabatic levels of the 3-site Hamiltonian during one period of a pumping cycle. In the absence of coupling ( $c_1 = c_2 = 0$ ) the  $E_0 = u(t)$  level intersects the symmetric  $E_+ = 1$  level. With non zero coupling these intersections become avoided crossings, and the particle follows adiabatically the thickened lines. For presentation purpose we indicate that either  $c_1$  or  $c_2$  equal zero (“blocked”), but in the general analysis we allow any splitting ratio, including the possibility  $c_1 = c_2$  of having the same amplitude to take either of the two paths.

nal to noise ratio?

**Outline.** – In the next section we define the model and the counting operator  $Q(t)$ . In sections 3 and 4 we discuss the restricted quantum-classical correspondence that applies to the analysis of single path crossing, while in sections 5 we consider multiple path geometries. How to treat interference in a sequence of Landau-Zener crossings and the analysis of quantum stirring are discussed in section 6. The long time counting statistics is discussed in sections 7 and 8. The relation to the theory of spreading and dissipation is illuminated in section 9. The main observations are summarized in section 10.

## 2. Modeling

We consider the 3 site system of Fig.1 which is described by the Hamiltonian

$$\mathcal{H} = \begin{pmatrix} u & c_1 & c_2 \\ c_1 & 0 & 1 \\ c_2 & 1 & 0 \end{pmatrix} \quad (1)$$

We label the sites by  $i = 0, 1, 2$ . We have control over the potential  $E_0 = u$  of the left site ( $\#0$ ). The two right sites ( $\#1$  and  $\#2$ ) are permanently coupled to each

other forming a double well with energy levels  $E_- = -1$  and  $E_+ = +1$ . We also have relatively small couplings ( $|c_1|^2, |c_2|^2 \ll 1$ ) that allow transitions between the left and the right sites.

Later we consider the stirring cycle which is described in Fig.2. Its operation is inspired by the common peristaltic mechanism. Namely, the coupling constants  $c_1$  and  $c_2$  are regarded as “valves”. In the first half of the cycle  $c_2 = 0$  and  $u$  is raised, leading to an adiabatic transfer from-left-to-right via the  $0 \mapsto 1$  bond. In the second half of the cycle  $c_1 = 0$  and  $u$  is lowered, leading to an adiabatic transfer from-right-to-left via the  $0 \mapsto 2$  bond. The net effect is to pump one particle per cycle.

The matrix representation of the operator which is associated with the current through the  $0 \mapsto 1$  bond is

$$\mathcal{I} = \begin{pmatrix} 0 & ic_1 & 0 \\ -ic_1 & 0 & 0 \\ 0 & 0 & 0 \end{pmatrix} \quad (2)$$

In the Heisenberg picture the time dependent current operator is defined as  $\mathcal{I}(t) = U(t)^\dagger \mathcal{I} U(t)$ , where  $U(t)$  is the evolution operator. Consequently the counting operator is defined as

$$\mathcal{Q} = \int_0^t \mathcal{I}(t') dt' \quad (3)$$

The counting operator, unlike the current operator, is *not* a conventional observable in quantum mechanics. What can be measured in practice are only the first two moments of  $\mathcal{Q}$ , which are  $\langle \mathcal{Q} \rangle$  and  $\text{Var}(\mathcal{Q})$ . Still, on the mathematical side, it is convenient to treat  $\mathcal{Q}$  the same way as one treats conventional observables. Namely, to regard its eigenvalues  $Q_r$  as the possible outcomes of a measurement, and to associate with a given preparation  $\psi$  a probability distribution

$$P(Q_r) = |\langle Q_r | \psi \rangle|^2 \quad [\text{naive!}] \quad (4)$$

We shall refer to Eq.(4) as the *naive* definition of the full counting statistics. The physical definition of  $P(Q)$  is much more complicated [3,4], but it leads to the same first and second moments [9]. In the present paper we are not interested in the *full* counting statistics, but only in the first two moments, and therefore, for presentation purpose, we adopt the *naive* point of view.

### 3. Single path crossing

Let us consider first the very simple case of 2-site systems with left site (#0) and right site (#1). The particle is prepared in the left site and after some time has some probability  $p$  to be found in the right site. This probability can be regarded as the expectation value of the occupation operator  $\mathcal{N}$  that has the eigenvalues 0 or 1 depending on whether the particle is in state #0 or state #1.

In the classical analysis the possible outcomes of a measurement are  $N = Q = 1$  if the particle goes from left to right, and  $N = Q = 0$  otherwise. Obviously one should find out that

$$P(Q) = \begin{cases} p & \text{for } Q = 1 \\ 1-p & \text{for } Q = 0 \end{cases} \quad (5)$$

It follows that the  $k$ th moment is  $\langle Q^k \rangle = p$  and therefore

$$\langle \mathcal{Q} \rangle = p \quad (6)$$

$$\text{Var}(\mathcal{Q}) = (1-p)p \quad (7)$$

In the quantum mechanical treatment the counting operator is the integral over the current operator which has zero trace, so it should also be a  $2 \times 2$  traceless Hermitian matrix which we write in the  $i=0, 1$  basis as

$$\mathcal{Q} = \begin{pmatrix} +Q_{\parallel} & iQ_{\perp} \\ -iQ_{\perp}^* & -Q_{\parallel} \end{pmatrix} \quad (8)$$

If the particle is initially prepared in the #0 site then  $\langle \mathcal{Q} \rangle = Q_{\parallel}$  and  $\text{Var}(\mathcal{Q}) = |Q_{\perp}|^2$ . So now the question arises whether one should expect an agreement between the quantum result and the classical results for the first and second moments. In the next section we argue that for a single path geometry the answer is *yes*: The first and second moments of  $Q$  should both equal  $p$ . It follows that the matrix that represents the counting operator in the  $i=0, 1$  basis is expressible in terms of  $p$  and an extra phase:

$$\mathcal{Q} = \begin{pmatrix} +p & i\sqrt{(1-p)p} e^{i\phi} \\ -i\sqrt{(1-p)p} e^{-i\phi} & -p \end{pmatrix} \quad (9)$$

Later we are going to use this expression as a building block in the analysis of a multiple crossing scenario.

For completeness we note that from the above analysis it follows that the eigenvalues of the counting operator are  $Q_{\pm} = \pm\sqrt{p}$  with

$$P(Q) = \begin{cases} (1+\sqrt{p})/2 & \text{for } Q = Q_- \\ (1-\sqrt{p})/2 & \text{for } Q = Q_+ \end{cases} \quad (10)$$

which should be contrasted with Eq.(5). The proper analysis [9] of the *full* counting statistics gives a more complicated quasi-distribution that neither agrees with the naive nor with the classical result, but still has the same first and second moments.

The above analysis has assumed nothing about the detailed form of the  $2 \times 2$  Hamiltonian. We merely had assumed that the particle was prepared in site #0, and that after time  $t$  there is some probability  $p$  to find the particle in site #1. However, in the later sections we are going to discuss specifically adiabatic crossings. During such a process the on-site energies ( $E_0=u(t)$  and  $E_1=\text{const}$ ) cross each other, and due to the inter-site coupling ( $=c$ ) the particle is adiabatically transferred from #0 to #1. Still there is some small probability for a non-adiabatic transition, so called Landau-Zener transition [11], that would leave the particle in #0. There is a well known formula, that allows to calculate the probability of such transition:

$$P_{LZ} = \exp\left[-2\pi\frac{c^2}{u}\right] \quad (11)$$

Consequently the probability to find the particle in the right side at the end of the process is

$$p = 1 - P_{LZ} \quad (12)$$

Note that it becomes 100% in the strict adiabatic limit.

#### 4. Quantum-classical correspondence

For a single path transition we can prove that the first two moments of  $\mathcal{Q}$  should be in agreement with the classical expectation. This is based on the relation between the occupation operator  $\mathcal{N}$  (whose eigenvalues are 0 and 1), and the counting operator  $\mathcal{Q}$  (whose eigenvalues do not have a classical interpretation). The relation is implied by the Heisenberg picture equation of motion:

$$\frac{d}{dt}\mathcal{N}(t) = \mathcal{I}(t) \quad (13)$$

Integrating over time we get

$$\mathcal{N}(t) - \mathcal{N}(0) = \mathcal{Q} \quad (14)$$

Assuming that the particle is initially prepared in the left site we get for the  $k = 1, 2$  moments of  $\mathcal{Q}$

$$\langle \mathcal{Q}^k \rangle = \langle (\mathcal{N}(t) - \mathcal{N}(0))^k \rangle = \langle \mathcal{N}^k \rangle_t = p \quad (15)$$

It is important to realize that the derivation cannot be extended to the  $k > 2$  moments because  $\mathcal{N}(t)$  does not commute with  $\mathcal{N}(0)$ . In fact it is not difficult to calculate the higher moments: one just has to realize that from Eq.(9) it follows that  $\mathcal{Q}^2 = p\mathbf{1}$ , and consequently the even moments are  $p^{k/2}$ , while the odd moments are  $p^{(k+1)/2}$ . Optionally this result can be obtained from Eq.(10) as in [9].

In the single path transition problem we say that we have *restricted* quantum-classical correspondence. The first two moments come out the same as in the classical calculation. Encouraged by this observation let us speculate what should be the results in more complicated circumstances that involve multiple path geometries...

Let us consider our 3 site system (Fig.1). We would like to analyze the first half of the cycle which is described by Fig.2. The particle is initially prepared in the left site. We gradually raise  $u$  so as to have an *adiabatic* transfer of the particle to the right side. The occupation probability of the right side at the end of the process is denoted by  $p$ . But now we have to remember that the particle could get there either via the  $0 \mapsto 1$  bond or via the  $0 \mapsto 2$  bond. Motivated by a stochastic point of view one may argue that the process is like *partitioning* of a current, and therefore

$$\langle \mathcal{Q} \rangle = \lambda p \quad (16)$$

$$\text{Var}(\mathcal{Q}) = (1 - \lambda p)\lambda p \quad [\text{stochastic}] \quad (17)$$

where the splitting ratio is

$$\lambda = \frac{|c_1|^2}{|c_1|^2 + |c_2|^2} \quad [\text{stochastic}] \quad (18)$$

If for example we have a strict adiabatic process with  $p = 1$  and the splitting ratio is  $\lambda = 1/2$ , then the stochastic expectation is to have  $\text{Var}(\mathcal{Q}) = (1/2)^2$ . Furthermore, considering a multi-cycle stirring process,

one may argue that the variance should be accumulated in a stochastic manner:

$$\text{Var}(Q) \propto \text{time} \quad [\text{stochastic}] \quad (19)$$

All the results above that are labeled as ‘stochastic’ might apply in the case of a non-coherent processes, or in the case of open geometries with leads attached to equilibrated reservoirs. Below we are going to show that the above ‘stochastic’ results do not apply to the analysis of coherent transport in multiple path closed geometries.

## 5. Double path adiabatic crossing

For  $c_1 = c_2 = 0$  the 3 site Hamiltonian of Eq.(1) is diagonal in the  $|E_0\rangle, |E_-\rangle, |E_+\rangle$  basis. If we limit ourselves to processes which involve adiabatic crossings of  $|E_0\rangle$  and  $|E_+\rangle$ , as in Fig.2, then transitions to  $|E_-\rangle$  can be neglected and we can work with a  $2 \times 2$  Hamiltonian in the  $|E_0\rangle$  and  $|E_+\rangle$  representation

$$\mathcal{H} = \begin{pmatrix} u(t) & c \\ c & 1 \end{pmatrix} \quad (20)$$

where  $c = (c_1 + c_2)/\sqrt{2}$ . In the same representation the current operator of Eq.(2) takes the form

$$\mathcal{I} = \lambda \begin{pmatrix} 0 & ic \\ -ic & 0 \end{pmatrix} \quad (21)$$

where the splitting ratio is

$$\lambda = \frac{c_1}{c_1 + c_2} \quad (22)$$

which should be contrasted with the stochastic expression Eq.(18). If we had  $\lambda = 1$  it would be the same problem as single path crossing. The multiple path geometry is reflected in having  $\mathcal{I} \mapsto \lambda\mathcal{I}$  and consequently  $\mathcal{Q} \mapsto \lambda\mathcal{Q}$ . It follows that

$$\langle \mathcal{Q} \rangle = \lambda p \quad (23)$$

$$\text{Var}(Q) = \lambda^2(1 - p)p \quad (24)$$

The latter expression for the variance should be contrasted with the stochastic expression Eq.(17). We now

turn to discuss two surprises that are associated with the above results.

The first surprise comes out from Eq.(22): it is the possibility to have  $\lambda$  outside of the range  $[0, 1]$ . This happens if  $c_1$  and  $c_2$  are opposite in sign and close in absolute value. So we can cook a cycle such that the splitting is into 700% in one path and  $-600\%$  in the other. What does it mean? After some reflection one realizes that a proper way to describe the dynamics is to say that the driving  $\dot{u}$  induces a circulating current in the system. Using a classical-like phrasing one may argue that during the transition the particle can encircle the ring 6 times before it makes the final crossing to the right side.

The second surprise comes out from Eq.(24): it is the way in which  $\lambda$  appears in the variance calculation. Consider for example a strict adiabatic process with  $p = 1$ . If say  $\lambda = 1/2$  we do not get  $\text{Var}(Q) = (1/2)^2$  but rather  $\text{Var}(Q) = 0$ . One may say that we do not have an incoherent partitioning of the current, but rather a noiseless exact splitting of the wavepacket. This should be contrasted with the common picture of getting shot noise due to partition of current in open geometries.

## 6. Quantum stirring

We can use the results that have been obtained in previous sections in order to calculate  $Q$  for the full stirring cycle which is described in Fig.2. For this purpose we regard the full stirring cycle as a sequence of two Landau Zener crossings, where the first is characterized by a splitting ratio  $\lambda_{\odot}$  while the second is characterized by a different splitting ratio  $\lambda_{\ominus}$ . The net effect is

$$\langle \mathcal{Q} \rangle = \lambda_{\odot} - \lambda_{\ominus} + \mathcal{O}(PLZ) \quad (25)$$

An optional way to derive this result is to make a full 3 level calculation using the Kubo formula [8]. Here we have bypassed the long derivation by making a reduction to a multiple path crossing problem. The naive expectation is to have  $|\mathcal{Q}| < 1$  if the valves are leaky. But by playing with the splitting ratio we can get  $|\mathcal{Q}| \gg 1$  per cycle. In the language of the Kubo formalism [8,6] this happens if the pumping cycle encloses a degener-

acy. A large  $\mathcal{Q}$  reflects a huge circulating current which is induced by the driving.

We can regard the stirring as an induced persistent current. Having figured out what is  $\langle \mathcal{Q} \rangle$ , the next challenge in line is to calculate the variance  $\text{Var}(\mathcal{Q})$ . For this purpose we regard the full stirring cycle as a sequence of two Landau Zener crossings. The one period evolution operator can be written as

$$U(\text{cycle}) = \left[ T U_{\text{LZ}}^{\circ} T \right] e^{-i\varphi} \left[ U_{\text{LZ}}^{\circ} \right] \quad (26)$$

We now explain the ingredients of this expression. The adiabatic approximation for the  $U_{\text{LZ}}$  of a single Landau-Zener crossing is well known (see e.g. [12]):

$$U_{\text{LZ}} \approx \begin{pmatrix} \sqrt{P_{\text{LZ}}} & -\sqrt{1-P_{\text{LZ}}} \\ \sqrt{1-P_{\text{LZ}}} & \sqrt{P_{\text{LZ}}} \end{pmatrix} \quad (27)$$

In the strict adiabatic limit  $P_{\text{LZ}} = 0$  and we denote the respective matrix by  $U_{\text{LZ}}^{(0)}$ . In the first and second crossings  $P_{\text{LZ}}$  might be different and accordingly we use the notations  $U_{\text{LZ}}^{\circ}$  and  $U_{\text{LZ}}^{\circ}$ . The diagonal matrix  $\varphi = \text{diag}\{\varphi_+, \varphi_-\}$  contains the dynamical phases that are accumulated in the upper and lower levels during the time between the two crossings, and we use the notation  $\tilde{\varphi}$  for the phase difference. The transposition operator  $T$  is required because in the second half of the cycle the roles of the lower and the upper states are interchanged. The expression for the total Landau-Zener transition probability is an interference of the two possible ways to get to the upper level, either by making the transition in the first crossing or in the second crossing:

$$p \approx \left| \sqrt{P_{\text{LZ}}^{\circ}} - e^{i\tilde{\varphi}} \sqrt{P_{\text{LZ}}^{\circ}} \right|^2 \quad (28)$$

Physically  $p$  is the probability *not* to come back to the initial site. The strict adiabatic limit is  $p = 0$ .

We turn now to calculate  $\mathcal{Q}$  in leading order for  $P_{\text{LZ}} \ll 1$ . The operator  $\mathcal{Q}_{\text{LZ}}^{\circ}$  is obtained by integrating over  $\mathcal{I}(t) = U(t)^{\dagger} \mathcal{I} U(t)$  with  $U(t) = U_{\text{LZ}}^{\circ}(t)$ . But in the second half of the cycle  $U(t)$  is given by Eq.(26), with  $U_{\text{LZ}}^{\circ}$  replaced by  $U_{\text{LZ}}^{\circ}(t)$ . Consequently we get

$$\int \mathcal{I}(t) dt \approx \mathcal{Q}_{\text{LZ}}^{\circ} - [T e^{-i\varphi} U_{\text{LZ}}^{\circ}]^{\dagger} \mathcal{Q}_{\text{LZ}}^{\circ} [T e^{-i\varphi} U_{\text{LZ}}^{\circ}]$$

The first term in this expression is Eq.(9) multiplied by  $\lambda_{\circ}$ , with the  $p$  of Eq.(12), and with  $\phi = -\pi/2$  cor-

responding to the phase convention in Eq.(27). Then the second term in this expression becomes

$$\lambda_{\circ} \begin{pmatrix} -(1 - \delta p) & i\delta q \\ -i\delta q & +(1 - \delta p) \end{pmatrix} \quad (29)$$

where

$$\delta p = +2P_{\text{LZ}}^{\circ} + P_{\text{LZ}}^{\circ} - 2\sqrt{P_{\text{LZ}}^{\circ}P_{\text{LZ}}^{\circ}} \cos(\tilde{\varphi}) \quad (30)$$

$$\delta q = -2\sqrt{P_{\text{LZ}}^{\circ}} + \sqrt{P_{\text{LZ}}^{\circ}} \exp(i\tilde{\varphi}) \quad (31)$$

It is easily verified that for  $\lambda = 1$  we have indeed an agreement with the restricted quantum-classical correspondence relation of Eq.(15) where  $p$  is given by Eq.(28). For  $\lambda \neq 1$  the result for the expectation value  $\langle \mathcal{Q} \rangle$  is in agreement with Eq.(25). For the variance we get

$$\text{Var}(\mathcal{Q}) \approx \left| \tilde{\lambda}_{\circ} \sqrt{P_{\text{LZ}}^{\circ}} + e^{i\tilde{\varphi}} \lambda_{\circ} \sqrt{P_{\text{LZ}}^{\circ}} \right|^2 \quad (32)$$

where  $\tilde{\lambda}_{\circ} = \lambda_{\circ} - 2\lambda_{\circ}$ . This is a generalization of a result that we had obtained using an adiabatic formalism in a previous publication [10]. The appearance of  $\tilde{\lambda}_{\circ}$  instead of  $\lambda_{\circ}$  reflects the definite site preparation at  $t = 0$ , and therefore it did not emerge in the adiabatic calculation where  $t = 0$  has no special meaning. Notice that the adiabatic approximation with  $\tilde{\lambda}_{\circ} = \lambda_{\circ}$  is formally obtained by replacing  $U_{\text{LZ}}$  with  $U_{\text{LZ}}^{(0)}$ .

One should realize that the interference expresses itself differently in the expressions for  $p$  and for  $\text{Var}(\mathcal{Q})$ . One may re-phrase this observation by saying that for a 3-site ring geometry, unlike the case of a 2-site geometry, there is no trivial relation between the counting statistics and the occupation statistics.

## 7. Long time statistics of induced currents

In this section we would like to consider the long time behavior of the counting statistics for either non-driven or periodically driven systems. In the latter context it is convenient to define  $U \equiv U(T)$  as the one-period (Floque) evolution operator, and  $\mathcal{Q} \equiv \mathcal{Q}(T)$  as the one-period counting operator, where  $T = 1$  is the period. The interest is in the counting statistics after  $t$  periods. Accordingly Eq.(3) takes the form

$$\mathcal{Q}(t) = \int_0^t \mathcal{I}(t') dt' = \mathcal{Q} + U^{-1} \mathcal{Q} U + \dots + U^{-t} \mathcal{Q} U^t$$

It should be clear that in this latter discrete version the operator  $\mathcal{Q}$  (which is like flow per period), plays the same role as the operator  $\mathcal{I}$  (flow per unit time). For this reason we are not going to duplicate the discussion below, and stick to continuous time notations. Having defined  $\mathcal{I}$  as the current through a specified bond (or more generally it would be replaced by the flow per-period), we can decompose it into a "DC" part and oscillatory part as follows:

$$\mathcal{I}(t) = \sum_{n,m} |n\rangle e^{i(E_n - E_m)t} I_{nm} \langle m| \equiv \bar{\mathcal{I}} + \delta\mathcal{I}(t) \quad (33)$$

where

$$\bar{\mathcal{I}} \equiv \sum_{E_n = E_m} |n\rangle I_{nm} \langle m| \quad (34)$$

In the absence of magnetic fields the stationary state of non-driven system is characterized by zero "DC" current and we get  $\bar{\mathcal{I}} = 0$ , unless the Hamiltonian has a degeneracy. For a periodically driven systems  $n$  are defined as the eigenstates of the Floque operator and in general we have  $\bar{\mathcal{I}} \neq 0$ . Accordingly

$$\mathcal{Q}(t) = t\bar{\mathcal{I}} + \sum_{E_n \neq E_m} |n\rangle \left[ i \frac{1 - e^{i(E_n - E_m)t}}{E_n - E_m} \right] I_{nm} \langle m|$$

The non-zero elements of the oscillatory term are all off-diagonal, while those of  $\bar{\mathcal{I}}$  may be both diagonal and non-diagonal. However, without loss of generality we can choose the  $n$  basis such that  $\bar{\mathcal{I}}$  is diagonal. If the preparation is a superposition of Floque eigenstates, then both the average and the dispersion grow linearly. Accordingly, in general, the asymptotic value of the relative dispersion  $\sqrt{\text{Var}(\mathcal{Q})}/\langle \mathcal{Q} \rangle$  does not go to zero. In order to make it go to zero we have to especially prepare the system in an  $n$  eigenstate. For such special preparation  $\langle \mathcal{Q}(t) \rangle$  grows linearly while the dispersion is oscillating around a constant value:

$$\begin{aligned} \text{Var}(\mathcal{Q}) &= \sum_m \frac{2|I_{nm}|^2}{(E_n - E_m)^2} [1 - \cos((E_n - E_m)t)] \\ &= \overline{\text{Var}(\mathcal{Q})} + \text{oscillations} \end{aligned} \quad (35)$$

The time averaged value of the dispersion  $\overline{\text{Var}(\mathcal{Q})}$  is given above by the first term (without the cosine). The time averaged value is not always of physical interest.

If only two levels are involved, then  $\text{Var}(\mathcal{Q})$  drops to zero periodically. This applies also if several levels are involved, as long as their spacing differences are not resolved. The example in the following section demonstrates these considerations.

## 8. Example for long time counting statistics

The simplest way to illustrate the discussion of the previous section is to consider the counting statistics which is associated with the persistent current in a clean ring. For simplicity we consider  $N$  site ring. The position eigenstates are labeled as  $x = 0, 1, 2, \dots$ , while the momentum eigenstates are labeled as  $p = k_n = (2\pi/N)n$  with  $n = 0, \pm 1, \pm 2, \dots$ . The Hamiltonian is

$$\mathcal{H} = -cD - cD^{-1} = -2c \cos(p) \quad (36)$$

where  $D = \exp(-ip)$  is the one site displacement operator, and  $c$  is the hopping amplitude. The eigen-energies are  $E_n = -2c \cos(2\pi n/N)$ . Thanks to the  $n \mapsto -n$  degeneracy of the spectrum the ring can support a persistent current even in the absence of a magnetic field. The velocity operator is a three diagonal matrix

$$v = i[\mathcal{H}, x] = icD - icD^{-1} = 2c \sin(p) \quad (37)$$

We measure the current through the  $0 \mapsto 1$  bond. Accordingly

$$\mathcal{I} = -ic [ |1\rangle \langle 0| - |0\rangle \langle 1| ] \quad (38)$$

We realize that

$$[\mathcal{I}(t)]_{nm} = -ic \frac{1}{N} [ e^{ik_n} - e^{-ik_m} ] e^{i(E_n - E_m)t} \quad (39)$$

Upon time averaging only the  $n = m$  terms survive and they equal  $-i(1/N)2c \sin(k_n)$ . Thus we have the identification

$$\bar{\mathcal{I}} = \frac{1}{N} v \quad (40)$$

If the energies were *equally* spaced with some level spacing  $\Delta = (2\pi/N)v_F$ , the motion of the particle would be strictly periodic. The period of the motion  $2\pi/\Delta$  would be the time to make one round along the ring. In such case one easily realizes that the variance  $\text{Var}(\mathcal{Q})$

becomes zero at the end of each period. But if one takes the true dispersion into account, one realizes that this periodicity is not strict: after some time the quasi-periodic (rather than periodic) nature of the motion is exposed. The long time average of the fluctuating variance can be calculated using Eq.(35), leading to:

$$\overline{\text{Var}(Q)} = \sum_{m \neq \pm n}^N \frac{2|I_{nm}|^2}{(E_n - E_m)^2} \approx \frac{1}{\pi^2} \sum_{\nu=1}^{\infty} \frac{1}{\nu^2} = \frac{1}{6} \quad (41)$$

Thus, even if a particle is prepared in a definite stationary velocity eigenstate, still the counting at the end of a period does not yield a *certain* result. This uncertainty is related to the non-linearity of the spectrum.

## 9. Counting, spreading, and dissipation

The analysis of the long time behavior of the counting statistics along the lines of the previous section is not very illuminating once we turn to consider driven systems of greater complexity. Technically this is because the quasi-energies, unlike  $E_n$  become dense in the  $[0, 2\pi]$  interval. It is therefore more illuminating to observe that in the latter case the theory of counting is strongly related to the theory of spreading in real or in energy space.

Let us assume that we have a ring, and that the current is measured through a section  $x$ . [In the tight binding model we can associate a location  $x_i$  with each site, and Eq.(38) is an example for an expression for the current through a section at  $x_0 < x < x_1$ ]. For a ring of length  $L$  it is convenient to re-define the current operator as:

$$\mathcal{I} := \frac{1}{L} \int_0^L dx \mathcal{I} = \frac{1}{L} v \quad (42)$$

which is essentially the velocity operator. Thus we get a relation between the counting operator and the spreading in real space

$$\mathcal{Q}(t) = \frac{1}{L} (x(t) - x(0)) \quad (43)$$

where  $x(t)$  is the non-periodic extension of the position operator. This procedure is nice but it should be clear that the re-definition of the current operator implies that possibly important information is lost.

More generally we can define an “associated” physical problem as follows. Assume that the particles are charged (for simplicity we set  $e = 1$ ), and the current is driven by an electro-motive-force (EMF) which is induced by a vector potential

$$A(x, t) = \Phi(t) \delta(x - x_0) \quad (44)$$

Then the rate of energy absorption is proportional to the current and to the EMF ( $-\dot{\Phi}$ )

$$\frac{d\mathcal{H}}{dt} = \frac{\partial \mathcal{H}}{\partial t} = \frac{\partial \mathcal{H}}{\partial \Phi} \dot{\Phi} = -\dot{\Phi} \times \mathcal{I} \quad (45)$$

Thus the transported charge  $\mathcal{Q}$  implies energy absorption

$$\mathcal{Q}_{\text{absorption}} \equiv (\mathcal{H}(t) - \mathcal{H}(0)) = -\dot{\Phi} \times \mathcal{Q} \quad (46)$$

The energy absorption can be either positive or negative, but if the system is chaotic it can be argued that its dispersion, and hence the average are growing as a function of time. The same applies to  $\mathcal{Q}$ . Namely:

$$\text{Var}(Q) = \int_0^t \int_0^t \langle \mathcal{I}(t) \mathcal{I}(t') \rangle dt dt' \quad (47)$$

Thus both the counting statistics and the dissipation reflect the fluctuations of the current (Kubo). This point of view is quite powerful. Instead of thinking about “counting statistics” (which is quite abstract) we can think about “energy absorption” for which we have better intuition and better theoretical tools for analysis.

## 10. Summary

In closed geometries counting statistics does not obey the common stochastic point of view, but rather reflects the coherent nature of the quantum transport. For a single path crossing in a 2 site system the first and second moments coincide with the naive classical expectation due to a restricted quantum-classical correspondence principle that can be established. But more generally, in multiple path geometries, the results are not as naively expected.

In a double path geometry the particle has two paths of transport. The splitting ratio  $\lambda$  would be in the range  $[0, 1]$  if the particle were classical. But in the case of coherent transport  $\lambda$  can be any number (either negative



or positive). We have explained what is the correct way to incorporate the splitting ratio  $\lambda$  in the calculation of the counting statistics.

During a double path crossing the probability amplitude of the particle is transported *simultaneously* via the two available paths. The coherent splitting is “exact”, and consequently  $Q$  has zero variance. If the particle had finite probabilities to go *either* via the first path *or* via the second path, it would imply a non-zero variance (which is not the case).

Possibly the most interesting result is the analysis of a full stirring cycle where the counting statistics becomes unrelated to the changes in the occupation statistics. In particular we showed that the interference of sequential Landau-Zener crossings is reflected differently in the respective expressions for  $\text{Var}Q$  and for  $p$ .

The RMS of the fluctuations of  $Q$  in a coherent stirring process grows like  $\propto t$  and not like  $\propto \sqrt{t}$ . This linear increase can be avoided, or at least minimized, if there is control over the preparation of the system. Then we are left with a constant residual dispersion. For a driven system the counting statistics is related to the study of spreading and dissipation in energy space, and hence the growth of the variance constitutes a reflection of linear response characteristics.

## Acknowledgments

The research was supported by a grant from the DIP, the Deutsch-Israelische Projektkooperation, and by a grant from the USA-Israel Binational Science Foundation (BSF).

## References

- [1] M. Buttiker, H. Thomas and A. Pretre, Z. Phys. B-Condens. Mat., **94** (1994) 133.
- [2] P. W. Brouwer, Phys. Rev. B **58** (1998) R10135.
- [3] L.S. Levitov and G.B. Lesovik, JETP Letters **55** (1992) 555; **58** (1993) 230.
- [4] Y.V. Nazarov and M. Kindermann, European Physical Journal B **35** (2003) 413.
- [5] Ya.M. Blanter and M. Buttiker, Physics Reports **336** (2000) 1, and references therein.
- [6] G. Rosenberg and D. Cohen, J. Phys. A **39** (2006) 2287.
- [7] I. Sela and D. Cohen, Phys. Rev. B **77** (2008) 245440.
- [8] D. Cohen, Phys. Rev. B **68** (2003) 155303.
- [9] M. Chuchem and D. Cohen, Phys. Rev. A **77** (2008) 012109.
- [10] M. Chuchem and D. Cohen, J. Phys. A **41** (2008) 075302.
- [11] C. Zener, Proc. R. Soc. Lond. A **317** (1932) 61.
- [12] E. Shimshoni and Y. Gefen, Ann. of Phys. **210** (1991) 16.